

Changing the Code / Combination Simplex 3000

Note: If your lock is opening on every turn of the knob or lever, except upon entering a code, this may be a ZERO CODE. Before attempting to remove the lock from the door, refer to the troubleshooting procedures outlined at bottom of this document for a zero code symptom/solution.

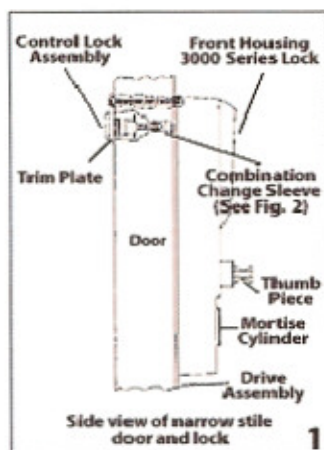

3000 Series FAQ Changing the Code / Combination

Important: Perform this procedure with the DOOR OPEN. The lock should be set for pushbutton access to retract latch.

Tools Required: DF59 Control Key & Small flat 1.8" blade screwdriver.

Read the instructions through once before attempting to change the combination.



The factory pre-set combination is 2 and 4 pressed simultaneously (and released), then press 3 (and release).

1. Remove the control lock assembly and trim plate using the DF59 Control Key provided with the lock (see figure 1). Turn the key to the left (counterclockwise) until control lock assembly can be removed and the combination change sleeve is exposed (see figure 2).

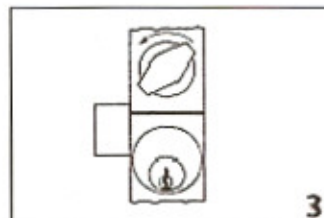

2. Turn the outside thumb piece to the left (counterclockwise) to the stop position and release. This clears the lock of previously used buttons (see figure 3).

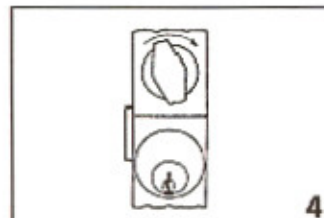

3. Enter the existing combination. Make sure you depress each button fully and release.

4. Insert screwdriver into combination change sleeve slot (see figure 2). Turn screwdriver to the right (clockwise) to the stop position. You should feel a slight click. Turn the screwdriver to the left (counterclockwise) to stop, and remove.

5. Rotate the thumb piece to the left (counterclockwise) to the stop position and release. This clears the old combination (see

figure 3).

6. Select a new combination, write it down. Some or all of the buttons may be used for your new combination - pressed individually or simultaneously. Each button may be used only once. We do not recommend the use of a one-button combination.

7. With the door open, enter your new combination. Depress each button fully and release it. You must feel a click each time you press a button to know that the button was fully depressed.

8. Turn the thumb piece to the right (clockwise) to the stop position to activate the new combination - note that latch is retracted. Release thumb piece (*see figure 4*).

9. Replace control lock assembly and trim plate by inserting threaded rod portion into the combination change sleeve and turning to the right (clockwise) until trim plate is snug up against stile of door. The DF59 Control Key can be removed from the control lock assembly in a vertical or horizontal position only.

10. BEFORE CLOSING THE DOOR, enter the new combination and turn the thumb piece to the right (clockwise) to insure proper retraction of latch.

Note:

- Do not force at any time.
- If a wrong combination is entered while operating the lock, turn the outside thumbturn to the left (counterclockwise) to the stop position and release. This will clear any previously depressed buttons. Enter in the correct combination.

Troubleshooting

Symptom/problem: Turning outside thumbturn clockwise always retracts latch without depressing any buttons.

Cause: Lock is in zero combination.

Solution: Follow the procedure for setting a new combination except omit step 3.