

# COBRA

BY SCHLAGE

## Installation Instructions and Programming Guide

### MPC COBRA

#### MANUALLY PROGRAMMABLE CYLINDRICAL LOCKING SYSTEM

The MPC Cobra is a battery-powered manually programmed access control system. Up to 100 individual codes can be programmed right at the keypad. A red and green LED on the keypad provide visual indication for programming and access events. Mechanical key override is possible when a 7-pin small-format interchangeable core (not included) is installed in place of the cylinder plug, which comes standard. Either the plug or the IC core must be

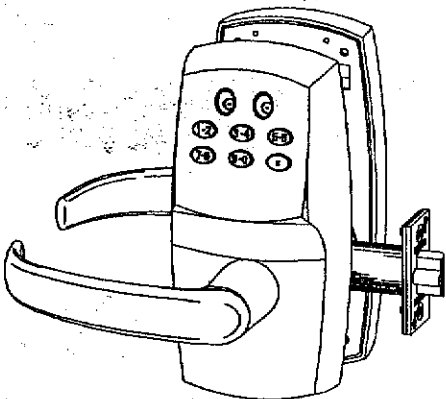

installed for the lock to operate. When the cylinder is removed (using the cylinder control key) the lock will unlock. Manual key override should only be necessary if the low battery output indications have been ignored. (See Battery Information on page 3). The design allows for mounting on doors from 1-1/2" to 2" thick. The retractor design allows easy adjustment for door thickness by rotation. A shim is available to mount the lock to a 1-3/8" door. An exterior gasket (EG option) is available for application to exterior sides of doors.

### DOOR, LATCH AND FRAME PREPARATION:

1

Use template or information below to prep door, latch and frame.

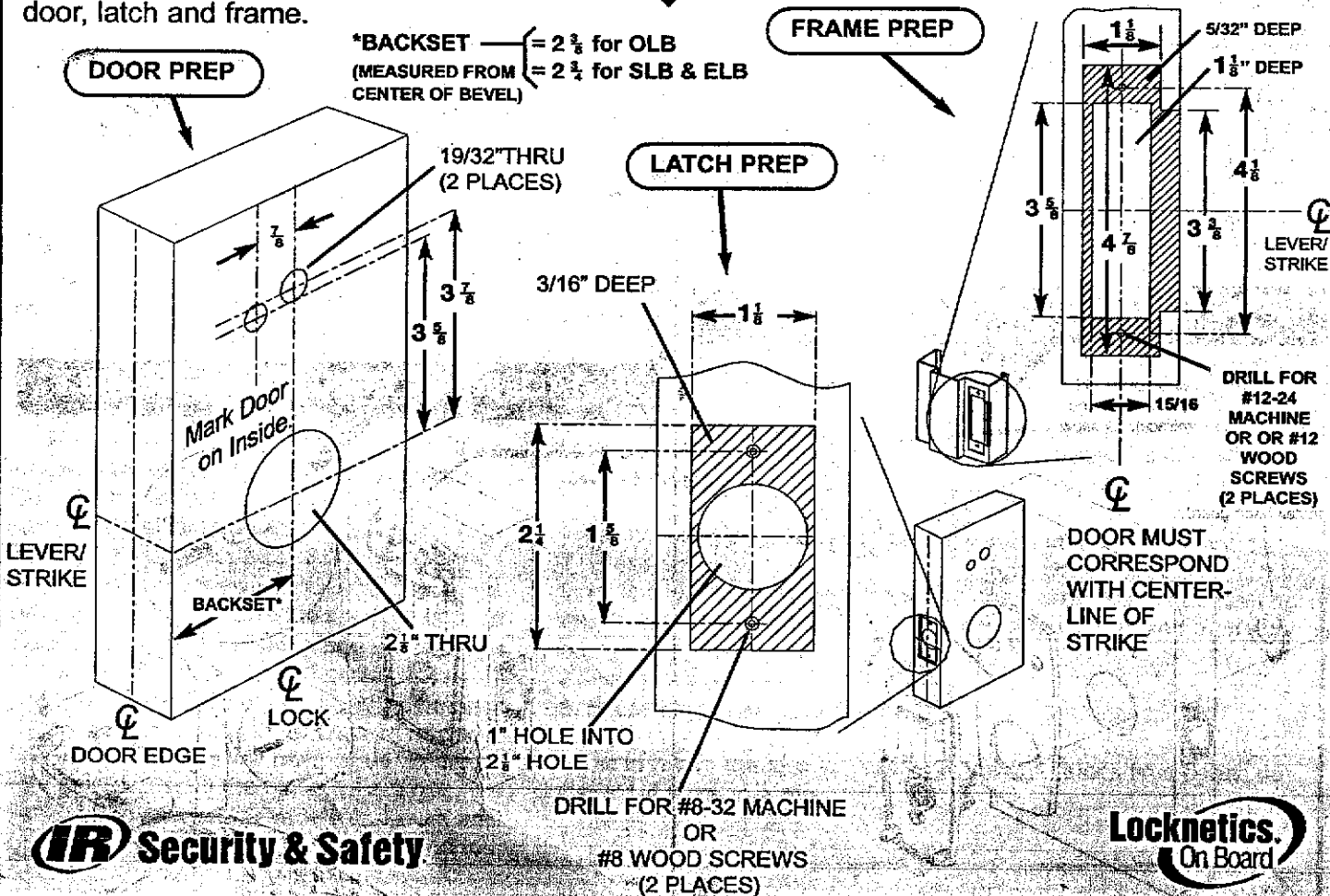

## PROGRAMMING STEPS:

Use the steps on this page to program codes into the lock. The "\*" key is used like the <ENTER> key is on a computer. After pressing the "\*" key, wait for the red and green LEDs to stop flashing before proceeding to the next step. If at any time the red LED stays on while the green LED flashes an error has occurred. The flashing message will repeat three times. Count the number of flashes and consult the error code chart below.

**TO ADD NORMAL USE CODE**

ENTER PROG. CODE \*  
 3 \*  
 ENTER NEW CODE \*  
 \* \*  
 TO ADD MORE  
 \* TO END

**TO ADD TOGGLE CODE**

ENTER PROG. CODE \*  
 33 \*  
 191 \*  
 ENTER NEW CODE \*  
 \* \*  
 TO ADD MORE  
 \* TO END

**TO ADD FREEZE/LOCKOUT CODE**

ENTER PROG. CODE \*  
 33 \*  
 115 \*  
 ENTER NEW CODE \*  
 \* \*  
 TO ADD MORE  
 \* TO END

**TO ADD ONE TIME USE CODE**

ENTER PROG. CODE \*  
 33 \*  
 113 \*  
 ENTER NEW CODE \*  
 \* \*  
 TO ADD MORE  
 \* TO END

**TO ADD SUPERVISED CODE**

ENTER PROG. CODE \*  
 33 \*  
 117 \*  
 ENTER NEW CODE \*  
 \* \*  
 TO ADD MORE  
 \* TO END

**TO ADD PASS THRU CODE**

ENTER PROG. CODE \*  
 33 \*  
 119 \*  
 ENTER NEW CODE \*  
 \* \*  
 TO ADD MORE  
 \* TO END

## FLASHES ERROR CODE DESCRIPTION

- |   |   |
|---|---|
| 2 | Code too long 8 digits max.   |
| 3 | Memory full, must delete some codes   |
| 4 | Can not delete Programming code - use Change steps.   |
| 5 | Second entry did not match first (Programming Code)   |
| 6 | Invalid entry, start over. (Verify that any codes entered prior to this error do not operate the lock.) |
| 7 | Code to be deleted does not exist.  |
| 8 | Duplicate code, code already exists.  |

**TO CHANGE PROGRAMMING CODE**

ENTER PROG. CODE \*  
 7 \*  
 ENTER NEW PROG. CODE \*  
 \* \*  
 ENTER NEW PROG. CODE AGAIN \*  
 \* \*

**TO DELETE CODES**

ENTER PROG. CODE \*  
 5 \*  
 ENTER CODE \*  
 \* \*  
 TO DELETE MORE  
 \* TO END

**TO CHANGE RELOCK TIME DELAY (DEFAULT 5 SEC.)**

ENTER PROG. CODE \*  
 99 \*  
 1 \*  
 PRESS 1 FOR 1 SEC. AND/OR 5 FOR 5 SEC. THE TIMES WILL ADD. 1  
 5  
 \* TO END

## INSTALLING 7-PIN SMALL-FORMAT IC CORE FOR MANUAL KEY OVERRIDE:

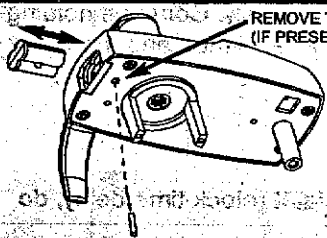

A. HOLD LOCK IN HORIZONTAL POSITION AS SHOWN AND PUSH PLUG IN UNTIL PIN FALLS OUT. REMOVE PLUG.

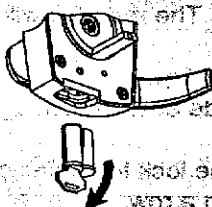

B. INSERT CYLINDER CONTROL KEY INTO CORE AND TURN CLOCKWISE TO RETRACT LOCKING PIN.

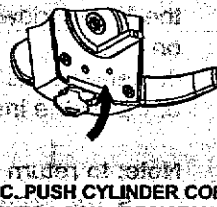

C. PUSH CYLINDER CORE INTO LOCK - RESISTANCE WILL BE NOTICEABLE. TURN KEY COUNTER-CLOCKWISE TO ENGAGE LOCKING PIN.

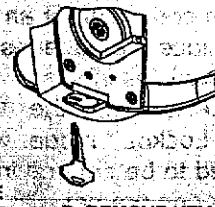

D. REMOVE KEY. LOCK IS NOW OPERATIONAL.

OPERATION: EITHER THE CYLINDER PLUG OR THE IC CORE MUST BE INSTALLED FOR THE LOCK TO OPERATE. REMOVAL OF THE CORE OR PLUG AUTOMATICALLY UNLOCKS THE LOCK. IT IS RECOMMENDED THAT AN IC CORE BE INSTALLED IN CASE IT EVER BECOMES NECESSARY TO UNLOCK THE LOCK USING MECHANICAL MEANS.

## PROGRAM LOCK CODES:

## 10

**Code Functions:**

The MPC Cobra is manually programmable to have up to 100 codes. The codes can have different functions as described below. Several types of functions have factory default values which are operational as soon as the lock is installed. It is highly recommended that the *Programming Code* be changed (this will delete all factory default codes) and new codes be added. In addition, it is recommended that at least one *Freeze/Lockout Code* be added - in case the batteries get completely drained. (See "Battery Information" on below.) All codes can be 3-8 digits in length (except the Programming code which must be 5-8 digits.) Keep a log of all issued codes. Issue codes exclusively with all odd or all even numbers - this practice will make it easier to spot duplicate codes, since each keypad button represents two numbers (for example, code 246 is identical to code 135.)

FUNCTION:	FACTORY DEFAULT:	DESCRIPTION:
PROGRAMMING	97531	The programming code puts the lock into a programming mode. It will not unlock the lock. When a Programming code plus "*" is entered the LEDs alternately flash several times indicating the lock is in a programming mode. If more than 30 seconds pass in between programming entries, the lock returns to a normal operational state.
NORMAL	13579	Normal codes unlock the lock for the relock time delay. While the lock is unlocked the green LED will flash. The LED will stop flashing and the lock will relock.
TOGGLE	135135	Toggle codes unlock the lock indefinitely. When the same (or another) toggle code is entered, the lock will immediately relock. When a toggle code is entered, the green LED will flash once. The LED will stop flashing and the lock will relock.
FREEZE/LOCKOUT	9115	Freeze/Lockout codes prevent other codes from working. The lock can be locked or unlocked when one is entered. If it is locked, a Pass Thru code will unlock it but all other codes will not. Only another Lockout code will reverse the effect.
ONE USE	NONE	One Use codes unlock the lock for the relock time delay. They will only work once and then are deleted from memory. They can be used again if they are programmed (added) into memory again.
SUPERVISED	NONE	Supervised codes require that two different supervised codes entered in order to unlock the lock for the relock time delay.
PASS THRU	NONE	Pass Thru codes will unlock the door for the relock time delay even if the door is in the lockout mode.

**BATTERY INFORMATION:**

The MPC Cobra uses four, standard AA batteries. The batteries should provide enough life for approximately 80,000 lock/unlock cycles. When the batteries are running out the lock provides two different modes of low battery indication: First, when a code is entered, the red LED will flash twelve times before the lock executes the command of the code. This is an indication that it is time to replace the batteries. The lock will go for about 500 cycles in this condition. After it reaches a certain point the lock will go into "Low Battery Lockout" mode. A Freeze/Lockout code will need to be entered in order to gain access. If the batteries are not changed, the lock will eventually not work and manual key override (if installed) will need to be used.

**CLEARING MEMORY:**

Clearing memory will delete all programmed codes and restore factory default codes. If the memory ever needs to be erased follow the steps below:

1. Remove the inside escutcheon. Remove one of the batteries.
2. Press any key.
3. Hold down the "\*" key and reinstall the battery. Continue holding the "\*" key down. The red LED will flash a few times and then stay on.
4. Release the "\*" key.
5. Install the inside escutcheon.

Note: to return the lock to the factory default relock time delay, do steps 1-4 twice in a row.

**INSTALL STRIKE & STRIKE BOX:**

**2**

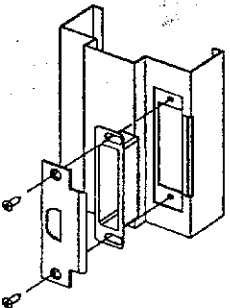

**INSTALL LATCH:**

**3**

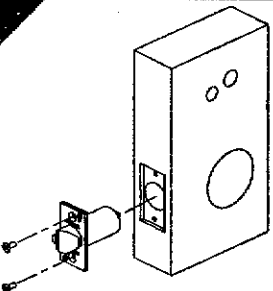

**SET RETRACTOR DEPTH:**

**4**

Screw retractor all the way in and unscrew it the correct number of turns according to door thickness:

**IMPORTANT!**  
FIRE PLATE IS FACTORY-INSTALLED AND MUST NOT BE REMOVED. IT WILL SNAP INTO THE 2-1/8" HOLE FOR THE RETRACTOR.

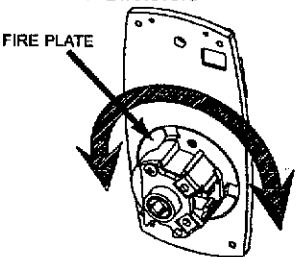

DOOR THICKNESS	NO. TURNS
1-3/8	0-1
1-1/2	0-1
1-5/8	1-2
1-3/4	2-3
1-7/8	3-4
2	4-5

**INSTALL INSIDE BASEPLATE ASSEMBLY:**

**5**

Make sure latch tabs engage the retractor as shown:

Install latch guard.

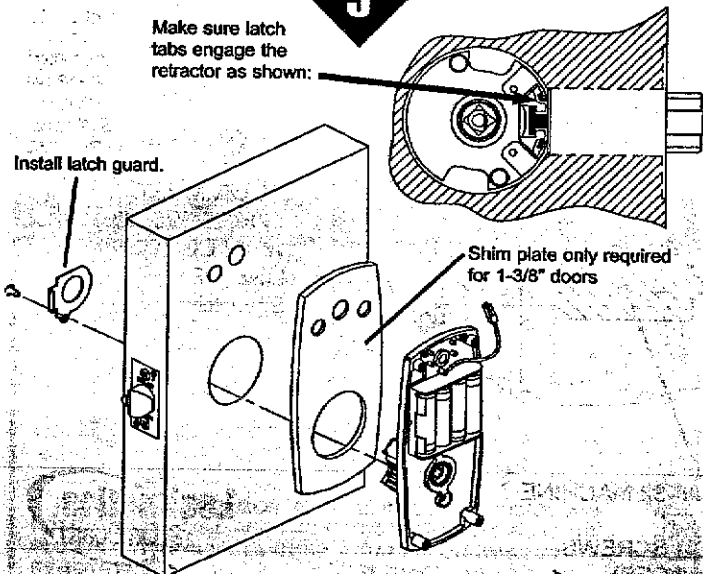

Shim plate only required for 1-3/8" doors

**INSTALL CYLINDER (RECOMMENDED):**

**6**

SEE PAGE 4 FOR INFORMATION REGARDING THE USE OF MECHANICAL KEY OVERRIDE AND INSTALLATION STEPS FOR 7-PIN SMALL FORMAT IC CORE.

**REVERSE LEVERS (IF REQUIRED):**

**7**

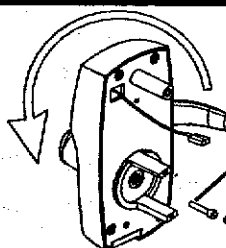

Apply Loctite™ 242 or equivalent to threads

**INSTALL OUTSIDE ESCUTCHEON/SPINDLE:**

**8**

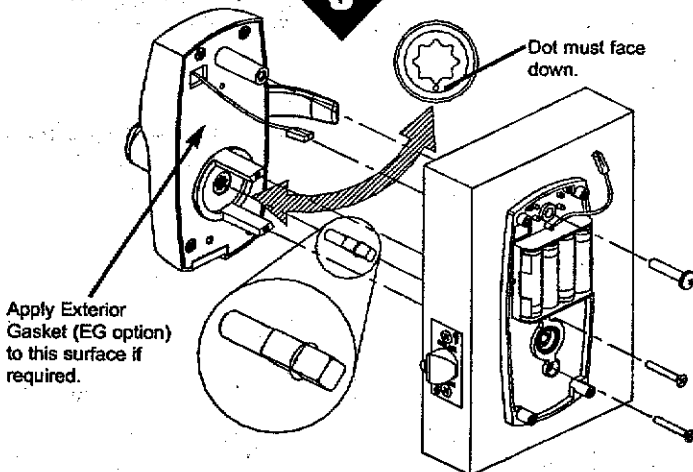

Dot must face down.

Apply Exterior Gasket (EG option) to this surface if required.

**INSTALL INSIDE ESCUTCHEON/SPINDLE:**

**9**

Plug in wiring harness

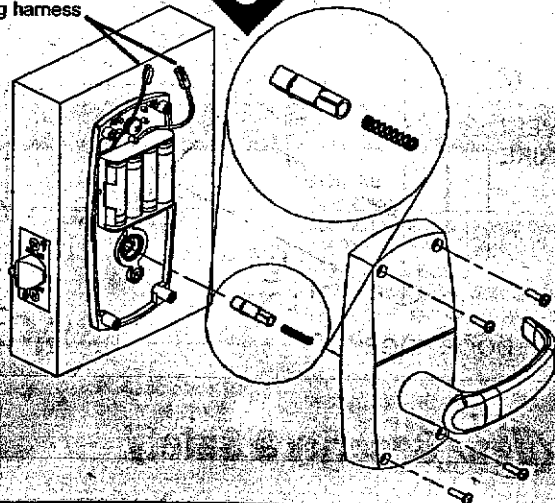

ME PREP

STRIKE BOX TO BE 1 1/8" DEEP TOTAL

←  $\phi$  OF STRIKE/LEVER

$\phi$  OF STRIKE/DOOR EDGE

THIS AREA TO BE 5/32" DEEP

LHR/LH

DOOR EDGE

1" DIA. INTO 2 1/8" THRU HOLE

$\phi$  OF 1 3/4" DOOR

$\phi$  OF 1 3/8" DOOR

#8-32 COMBINATION SCREWS (2)  
THIS AREA TO BE 3/16" DEEP

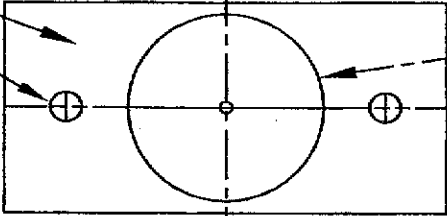

2-3/4" BACKSET

2-3/8" BACKSET

↓ HIGH EDGE

LOW EDGE ↓ HIGH EDGE

LOW EDGE

←  $\phi$  OF LATCH/LEVER/STRIKE



MPC Manually Programmable Cylindrical Lockset

PLACE TEMPLATE ON INSIDE (SECURED SIDE)

$\phi$  19/32" THRU

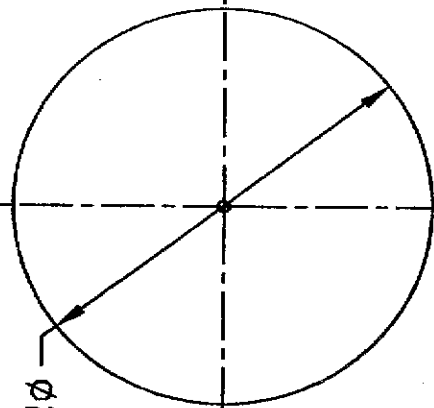
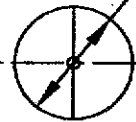
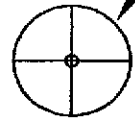

$\phi$  2 1/8" THRU

2-3/8" BACKSET

2-3/4" BACKSET

LOW EDGE

LOW EDGE ↑ HIGH EDGE

↑ HIGH EDGE

DOOR EDGE

RHR/RH

$\phi$  OF 1 3/4" DOOR

